

STYLE 816

Metal Choices:

FERACAST (Cast Iron)

Furnished with one coat of black paint

ALUMACAST (Cast Aluminum)

Furnished in natural metal finish

BRONZACAST (Cast Bronze)

Furnished in natural metal finish

Surface Design: Cross Hatched

Non-Slip cast metal stair nosing with #24 virgin grain Silicon Carbide abrasive granules embedded into the walking surface while the matrix is in a molten state.

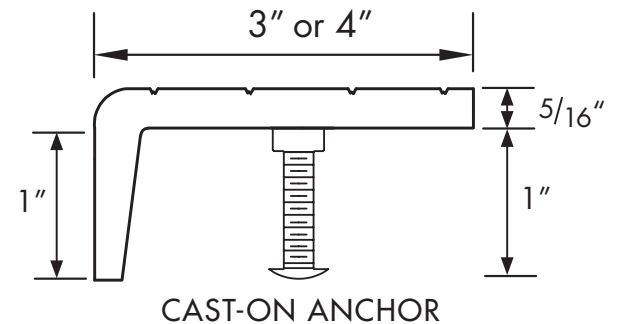
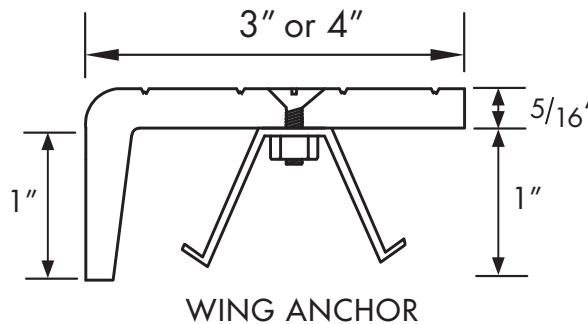
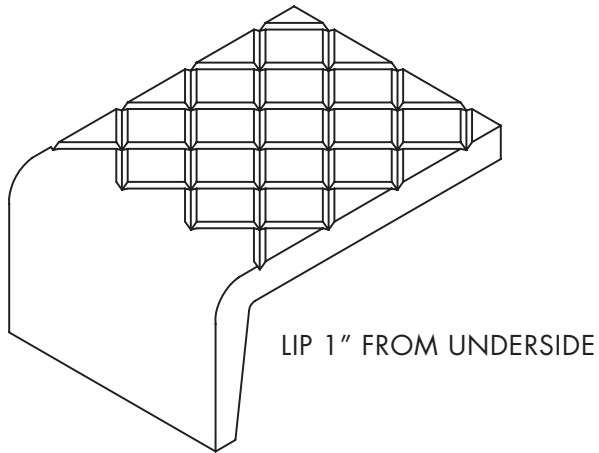

BILL OF MATERIAL

METAL CHOICE	QUANTITY	WIDTH	LENGTH	ANCHOR CHOICE	LOCATION

CUSTOMER:

PROJECT:

PO#:

DATE:

AMERICAN SAFETY TREAD CO., INC. • PO BOX 611 • HELENA, AL 35080

Phone: 800.245.4881 • 205.664.0511 • Fax: 205.663.9610

sales@americansafetytread.com • www.americansafetytread.com

