

# Style 817A

Metal Choices:

**FERACAST** (Cast Iron)

Furnished with one coat of black paint

**ALUMACAST** (Cast Aluminum)

Furnished in natural metal finish

**BRONZACAST** (Cast Bronze)

Furnished in natural metal finish

**Surface Design: Cross Hatched**

Non-Slip cast metal stair nosing with #24 virgin grain Silicon Carbide abrasive granules embedded into the walking surface while the matrix is in a molten state.

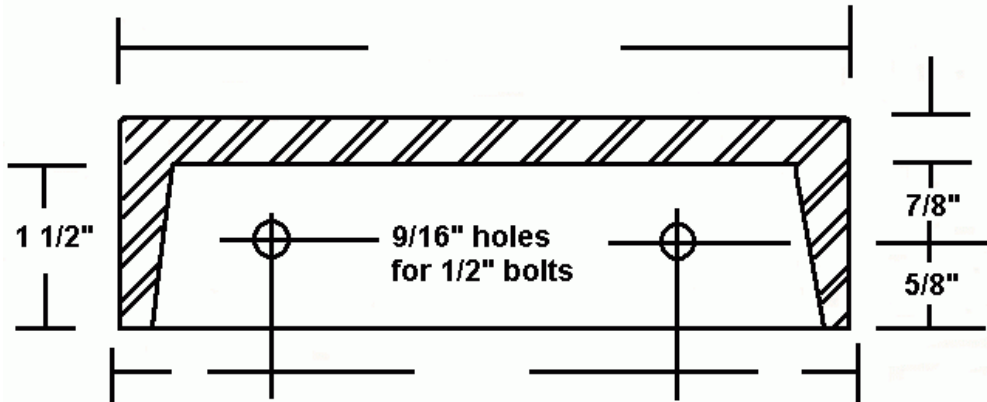

**Self supporting tread. Cast lugs at both ends permit direct mounting to stringers.**

**No risers or carrier angles are required**

**BILL OF MATERIAL**

METAL CHOICE	QUANTITY	WIDTH	LENGTH	ANCHOR CHOICE	LOCATION

**CUSTOMER:**

**PROJECT:**

**PO#:**

**DATE:**

AMERICAN SAFETY TREAD CO., INC. • PO BOX 611 • HELENA, AL 35080

Phone: 800.245.4881 • 205.664.0511 • Fax: 205.663.9610

sales@americansafetytread.com • www.americansafetytread.com

