

Style 950

Metal Choices:
FERACAST (Cast Iron)
 Furnished with one coat of black paint

ALUMACAST (Cast Aluminum)
 Furnished in natural metal finish

BRONZACAST (Cast Bronze)
 Furnished in natural metal finish

Surface Design: Cross Hatched
 Non-Slip cast metal stair nosing
 with #24 virgin grain Silicon Carbide
 abrasive granules embedded into the
 walking surface while the matrix is in
 a molten state.

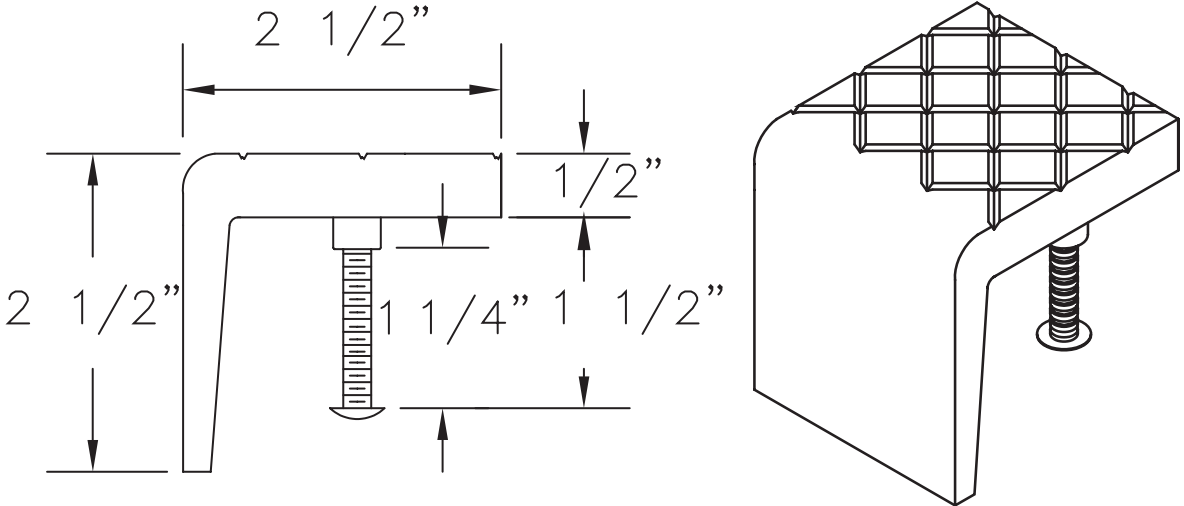

BILL OF MATERIAL

METAL CHOICE	QUANTITY	WIDTH	LENGTH	ANCHOR CHOICE	LOCATION

CUSTOMER:

PROJECT:

PO#:

DATE:

AMERICAN SAFETY TREAD CO., INC. • PO BOX 611 • HELENA, AL 35080
 Phone: 800.245.4881 • 205.664.0511 • Fax: 205.663.9610
 sales@americansafetytread.com • www.americansafetytread.com

